

Operating Instructions

AUTO-LOGIC™

TELEPHONE-ANSWERING
SYSTEM WITH FACSIMILE

MODEL NO. **KX-F115**

TELEPHONE

ANSWERING MACHINE

FACSIMILE

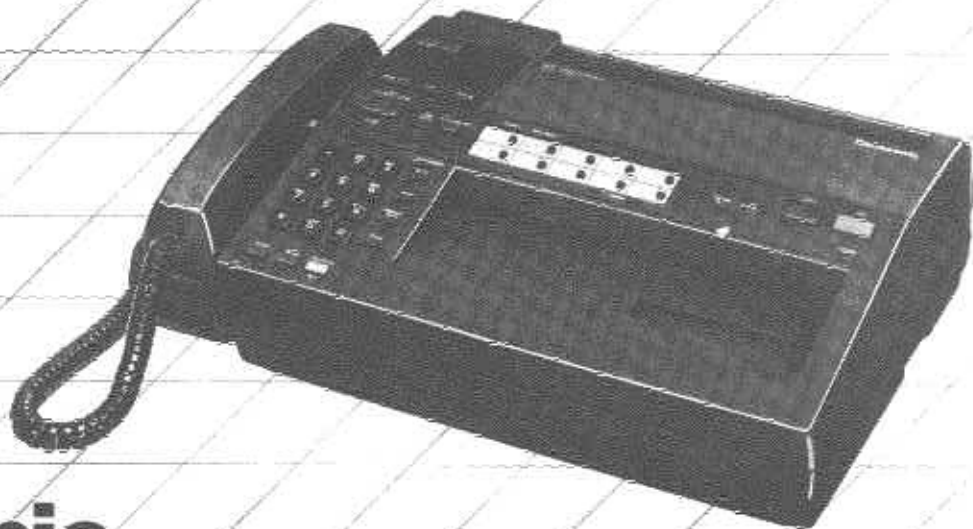

Panasonic

Please read before use.

Thank you for purchasing the Panasonic Telephone-Answering System with Facsimile.

Before reading these instructions, read the INSTALLATION MANUAL. Then install the unit and make the initial settings.

Features

• Answering Machine with Telephone and Facsimile

allows you to communicate with both voice and facsimile utilizing only one telephone line.

• Tone/Pulse Settings

allows tone or pulse dialing.

• Automatic Dialing and Speed Dialing

up to 20 stations (for automatic dialing) and 10 stations (for speed dialing) with each station capable of holding 30 digits. Each station can hold several telephone numbers for Call Hunting.

• Automatic Call Hunting

lets you store more than one telephone number in a station (up to 30 digits), so they can be dialed consecutively, up to 15 times if a busy signal is detected.

• Redial Memory Transfer

to store the Redial number into the memory of the Automatic and Speed dialers.

• One Touch Message Playback

automatically rewinds, plays messages, stops at last message and resets itself at the touch of a button.

• Tone Remote Control System

for Playback, Reset, Skip Forward, Back Space, OGM Recording, Marker Message, Remote Turn on, Memory Playback, OGM Skip and SP-Phone Turn on.

• Selectable Remote Code

to help protect from unauthorized message retrieval by remote.

• Message Memo Recording

to leave a personal message on the tape for later reference.

• Call Screening

to listen to your caller before picking up the receiver.

• Compatible with CCITT G2 and G3

• Automatic Receiving

allows you to receive a document without assisting.

• Automatic Fall Back Modem Speed

(9600/7200/4800/2400 bps)

• Copy Function

allows you to make a copy of a document.

The following may cause a fax communication to be aborted, or to have distorted characters.

- 1 If your telephone line is equipped with a call waiting service and a second call is received.
- 2 If a telephone which is connected in parallel, is picked up.

Accessories

Telephone Line Cord	1	Carrier Sheet	1
Incoming Message Tape	1	Leaflet (FAX CORRESPONDENCE)	1
Handset Cord	1	Quick Reference Sheet	
Handset	1	(for telephone and facsimile)	1
Recording Paper	1	AA size batteries	4
Quick Reference Card		Packed battery	1
(for answering machine)	1	Name Card (for automatic dialer)	1
		Name Card (for speed dialer)	1

Contents

Initial Preparation	3
Location of Controls	4
Foreword	5

TELEPHONE

Basic Operation

Manual Dialing and Receiving	6
Making a Call	
Receiving a Call	
Redialing	
Automatic Dialing and Speed	
Dialing	7
Programming	
Dialing	
Hands-free Operation	9
To Use the Handset	
To Use Hands-free Operation	
Helpful Hints for Hands-free Operation	
Hold	9
To Place a Call on Hold	
To Release Hold	

Detailed Operation

Mute Operation	10
Storing the Last Dialed Number (Redial Memory Transfer)	10
Outside Line or Computer Accessed Line (Pause Usage)	10
Automatic Call Hunting	11
Using One Memory Station	
Using Several Memory Stations	
Flash Function	12

ANSWERING MACHINE

Basic Operation

How to Record an Outgoing Message (OGM)	13
Recording and Confirmation	
Re-recording	
OGM Play Back	
Prior to Leaving	14
Preparation before Leaving	
Automatic Answering and Recording While an Incoming Message is being Recorded	

After Returning to Your Office	16
How to Listen to the Messages	
How to Save the Previously Recorded Messages	
How to Use Manual Quick Erase	16

Detailed Operation

How to Operate from a Remote Phone	17
How to Set the Remote Code	
How to Set to the Automatic Answer Mode from a Remote Phone	
How to Play Back Messages	
Back Space and Skip Forward	
Memory Playback	
Remote Reset of Tape	
Recording a Marker Message	
How to Change the Outgoing Message	
How to Turn on the Speakerphone (Answer- Back)	
OGM Skip	
Message Memo	21
How to Record a 2-Way Conversation	21

FACSIMILE

Basic Operation

Transmitting a Document	22
Recording OGM	
Transmissible Document	
Transmitting	
To Stop Transmission	
How to Transmit a Document to Your Unit from a Remote Location	
Receiving a Document	25

Detailed Operation

Information on Originals	26
Monitoring a Call	26
Making Copy	27
Copying	
Copy Pause	
Voice Contact	28
Initiating Contact during Transmission	
Initiating Contact during Reception	
Receiving a Request for Contact	
Selectors for Facsimile	29
Troubleshooting Guide	30

Initial Preparation

① DIALING MODE

Selector:

Set to "TONE".

If tone dialing is not available on your telephone line, set to "PULSE".

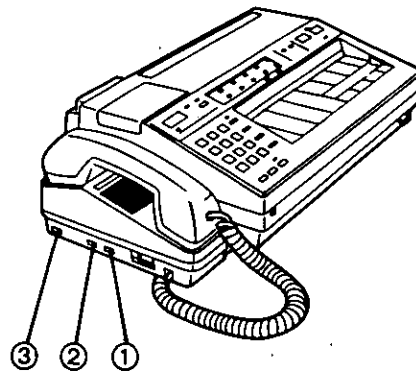

② RINGER VOLUME

Selector:

Set to "HIGH".

LOW: The ringer sound will be low.

OFF: The unit will not ring.



③ MEMORY Switch:

Set to "SET".

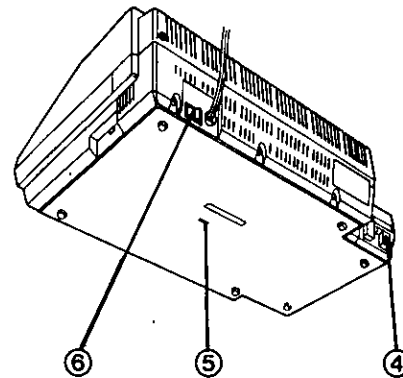

④ AUX. LEADS Switch:

Set to "OUT".

For further details, see page 9 in INSTALLATION MANUAL.



⑤ CPC Switch:

Set to "A".

For further details, see page 9 in INSTALLATION MANUAL.

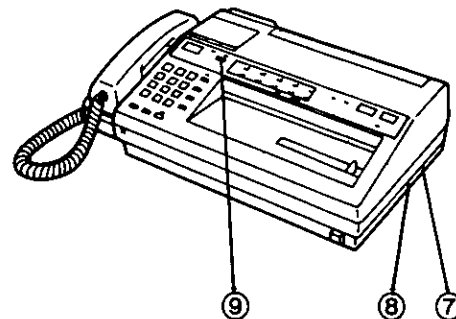
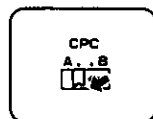

⑥ Set the POWER Switch on.

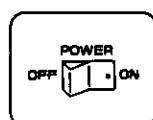

⑧ FAX-ATAS Selector:

Set to "ATAS/FAX".

For further details, see pages 5, 14 and 25.



⑦ RESOLUTION

Selector:

Set to "NORMAL".

If the letters and/or drawing in an original document are small or intricate, set to "FINE".



⑨ AUTO ANSWER

Button:

Push the button to cancel the Automatic Answer mode.

•The AUTO ANSWER indicator will go out.



Replace all of the AA size batteries every year and the packed battery every five years, or misoperation may occur. Do not use nickel-cadmium or alkaline cylindrical batteries.

■ If a power failure occurs, the unit can be used as a normal telephone.

Location of Controls

For your convenience, keep this page open when you read the following instructions.

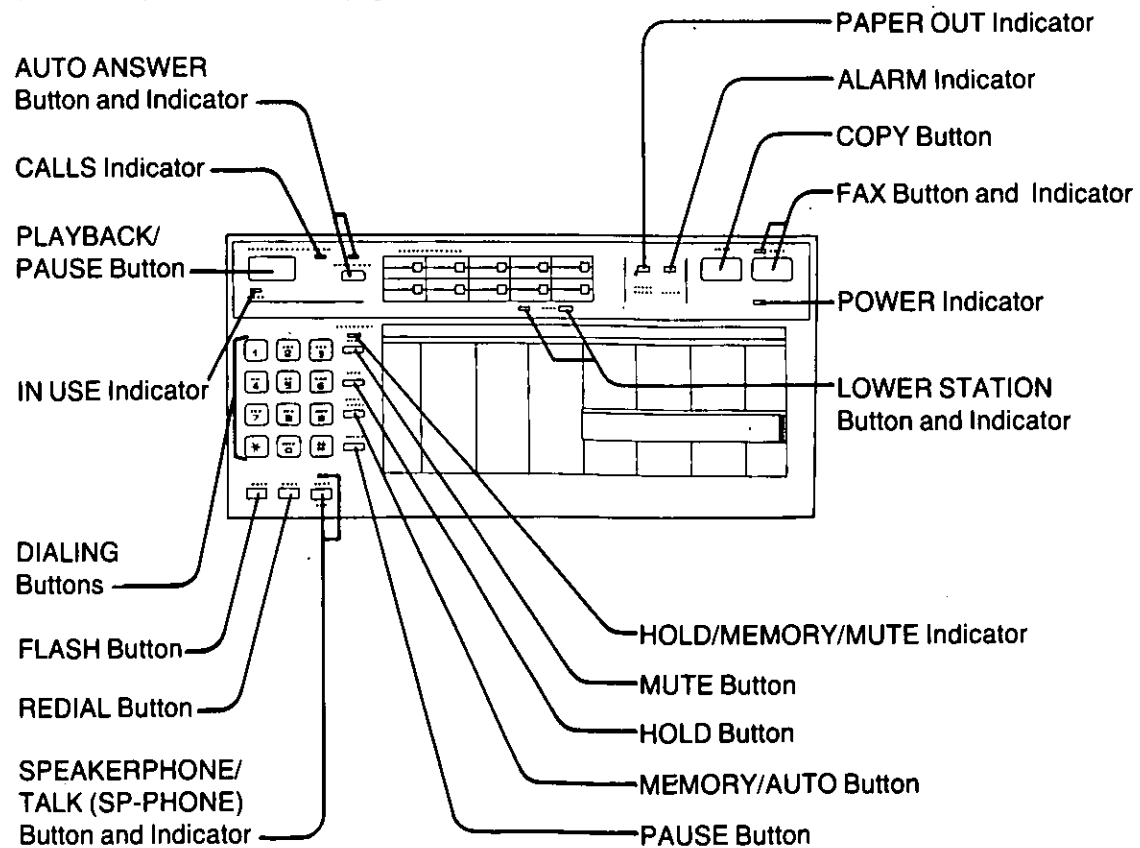
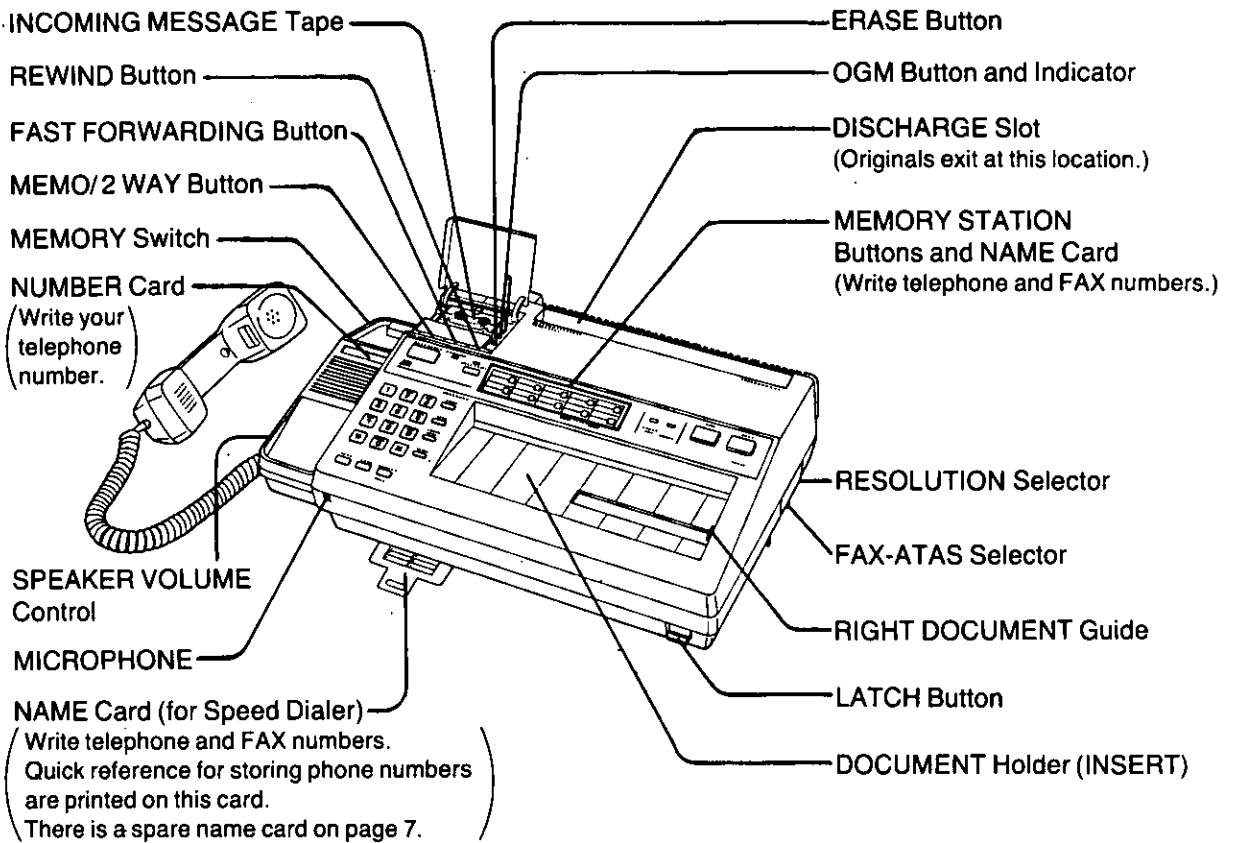

Foreword

This unit functions as an Answering Machine, Telephone and a Facsimile utilizing one telephone line. While the unit is set to the Automatic Answer mode and the FAX-ATAS selector is set to the "ATAS/FAX" position, the unit can automatically receive a transmitted document and/or record a voice-message. To automatically answer a call while in the ATAS/FAX, FAX or ATAS mode, push the AUTO ANSWER button on. The AUTO ANSWER Indicator will light.

- The unit requires a recording of an outgoing message beforehand to function in the Automatic Answer mode.
- The following functions will operate regardless of the selection of the Automatic Answer mode and the position of the FAX-ATAS selector.
Making a call, transmitting a document, making a copy, recording an outgoing message, playing back recorded message etc.
- The unit is equipped with a three position FAX-ATAS selector— ATAS/FAX, ATAS and FAX.

FAX-ATAS Selector

■ ATAS/FAX Position

When a call is received, the KX-F115 will answer and begin playing your recorded outgoing message.

Example of OGM

"This is the Panasonic Company. To send a FAX, push the [*] button. To leave a message, speak after the beep."

If the caller's voice is not heard within 5 seconds of the end of the OGM, the unit will automatically switch to the FAX mode to receive a transmitted document.

If a voice is detected (VOX), the unit will function as an answering machine.

While recording a caller's message, you may speak with him/her by lifting the handset or pushing the SP-PHONE button and speaking.

■ ATAS Position

When a call is received, the unit will function as an answering machine only.

Note:

The caller can change the unit to the FAX mode by pushing the [*] button.

■ FAX Position

When a call is received, the unit will function as a facsimile (FAX) machine only.

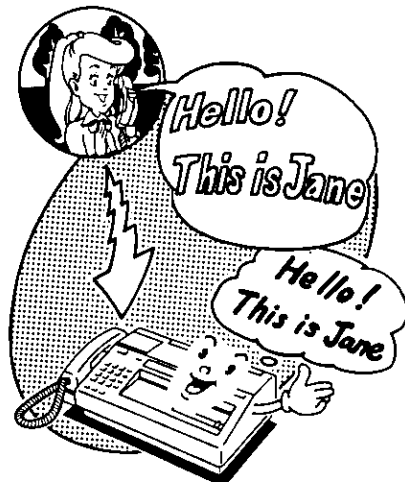

No OGM will be played and no messages can be left on the answering machine. Remote operation (from another phone) is also impossible.



Manual Dialing and Receiving

Making a Call



Using the Handset

- 1 Lift the handset .
- 2  the phone number and speak.
Push
- 3 When you have finished your conversation, hang up the .

Hands-free Operation

- 1   .
Push
 - The SP-PHONE indicator will light.
- 2  the phone number and speak.
Push
- 3 When you have finished your conversation,   again.
Push

Receiving a Call



- 1 Lift the  or   .
Push
- 2 Start speaking.

Helpful Hint

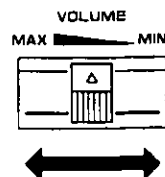
If it is difficult to hear the other party's voice when using the speakerphone, raise the sound level using the SPEAKER VOLUME control. Lower the sound level if the other party has difficulty hearing you.



Redialing

If the line is busy,   .
Push

- **When using the handset:**
Depressing the REDIAL button causes the last number to be redialed once.
- **When using the speakerphone:
(Automatic Redialing)**
The unit will automatically redial the last number dialed up to 15 times within a 10-minute period.

The SP-PHONE indicator will blink slowly.

•To cancel the automatic redialing, push the FLASH button.

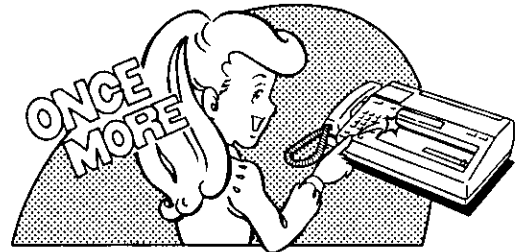

Automatic Dialing and Speed Dialing

The KX-F115 is equipped with a ten button automatic dialer. Each button has an upper and lower memory station, and each memory station can store a 30-digit (max.) telephone number.

The KX-F115 also allows keys [0] to [9] on the dial pad to be used as Speed Dial keys. Each of these keys is capable of storing a 30-digit telephone number.

Therefore, you can store 20 telephone/fax numbers, each with a maximum of 30 digits into the auto dialer, and an additional ten numbers into the speed dialer.

Programming

- Be sure that the batteries are installed, that the SP-PHONE button is off and that the handset is on the cradle.
- Set the MEMORY switch to "PROGRAM".
The MEMORY indicator will light.



Storage for Automatic Dialing

FAX numbers should be stored in the lower stations, since the lower stations are automatically selected when a document is placed in the DOCUMENT holder.

Example:

Storing FAX number 123-4567 into a lower memory station

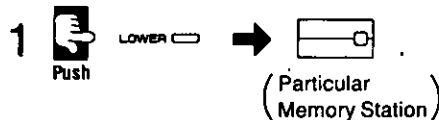

- The LOWER STATION indicator will light.
- When storing telephone number into the upper station, do not push the LOWER STATION button.

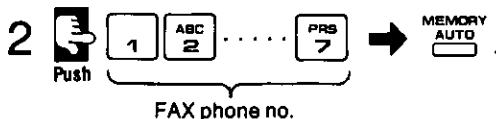

Storage for Speed Dialing

Example (When connected to a PBX):

Storing central office line access number 9 and phone number 234-5678 into memory station [0]

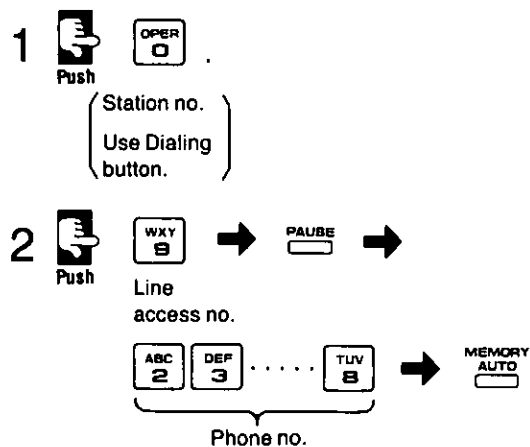

- See page 10 for use of the PAUSE button.

Spare Name Card

- 1 Detach this Name Card.
- 2 Write down the stored phone numbers.
- 3 Paste the Name Card on the sliding sheet.
(See page 4.)



Helpful Hints

- You may store telephone numbers into both upper and lower memory stations. You may also store FAX number similarly.
- While programming numbers into your auto and speed dialers, you can answer incoming calls by simply lifting the handset or pushing the SP-PHONE button. The programming mode will be cancelled, so you will have to reprogram the last station.
- Use "9" only when connected to a PBX.

NAME CARD FOR SPEED DIALER

1	6
2	7
3	8
4	9
5	0

To Correct an Error while Programming

 **CLEAR** instead of  until the MEMORY indicator lights.

- The new entry will be cleared and the previous storage will remain untouched.
- After pushing the CLEAR button, re-program the correct number.

To Change a Stored Number

Repeat "Storage for Automatic Dialing" or "Storage for Speed Dialing" on page 7.

To Confirm a Stored Number

Repeat the programming procedure using the same memory station and telephone number.

When the MEMORY button is pushed, a beep will be heard and the MEMORY indicator will flash.

- twice The entry is the same as was previously programmed.
- once The entry is different from the one that was previously programmed. Repeat the programming procedure.

To Erase after Programming

Example:
To erase the number from the upper station

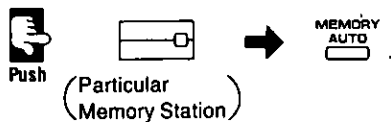

Example:
To erase the number from the memory station 0

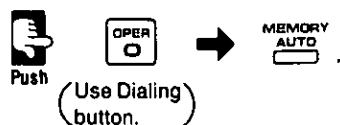

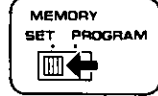

To Exit the Programming Mode

After programming all of the numbers, return the MEMORY switch to "SET".



Dialing





Automatic Dialing

- 1 Lift the  or  **SP-PHONE**.
Push
- When you push the SP-PHONE button, the SP-PHONE indicator will light.

- 2  **MEMORY AUTO**.
Push
(Particular Memory Station)

Speed Dialing

Example: Speed dialing the phone number stored in memory station 0

- 1 Lift the  or  **SP-PHONE**.
Push
- 2  **MEMORY AUTO** →  **OPER**.
Push
(Use as memory station.)

Helpful Hint

When you dial by using a lower memory station, you must first depress the LOWER STATION button, which will cause the LOWER STATION indicator to light.

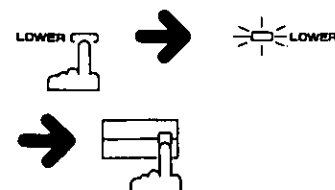

Hands-free Operation

You may choose to use the handset or the speakerphone.

To Use the Handset

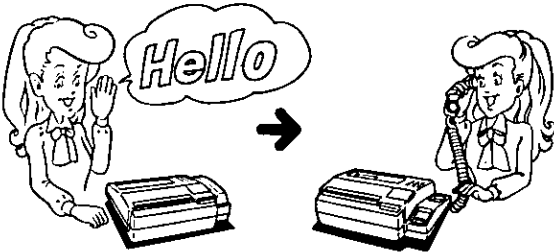



1 Lift the .

- The SP-PHONE indicator will go out.

2 Start speaking.

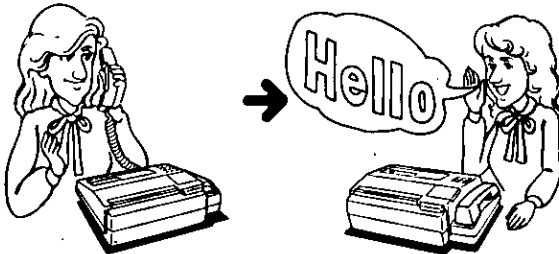
To Use Hands-free Operation



1  and start speaking.

- The SP-PHONE indicator will light.

2 Hang up the .

- If you hang up the handset before pushing the SP-PHONE button, the speakerphone will turn off.

Helpful Hints for Hands-free Operation

- **When the other party finds it difficult to hear your voice:**
Lower the sound level using the SPEAKER VOLUME control or speak louder.
- **Absorbing echoes:**
Use in a room which has curtains or carpeting.
- **To avoid lost or broken conversations:**
If some parts of the conversation are lost or broken, speak alternately.

Hold

To Place a Call on Hold

While having a conversation,  .

- Both you and the other party will hear a beep tone every 4.5 seconds. (Using the handset)
- The HOLD indicator will flash.
- You may hang up the handset without disconnecting the call.
If you place the handset on the cradle, the beep tones will not be heard.

To Release Hold

- **If the handset is off the cradle:**

 and start speaking.

- **If the handset is on the cradle:**

1 Lift the  or .

2 Start speaking.

Mute Operation

Use this feature when you do not want your voice to be heard by the other party.

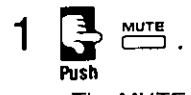

• The MUTE indicator will light.

2 To resume the conversation,



Storing the Last Dialed Number (Redial Memory Transfer)

It is possible to store the last manually dialed number, into an auto/speed dialer memory station.



Be sure that the handset is on the cradle and that the SP-PHONE button is off.

Example: To store the last dialed number into the upper station.

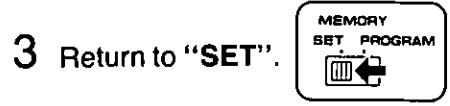
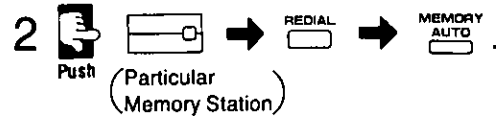

Outside Line or Computer Accessed Line (Pause Usage)

The PAUSE button function in a dial operation is helpful when accessing an outside line or Computer-Accessed long distance services.

■ One pause is required when waiting for an outside dial tone.

Example (PBX):

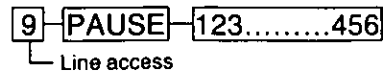

When dialing an access number manually, we recommend that you use a Pause as shown in the above example. Some PBX's require this Pause during an automatic redial.

■ Two pauses are required when waiting for a computer tone.

Example (For MCI, SPRINT, METRO and other systems):

Local access telephone number of the alternate long distance service company 121-5434, Authorization no. 5634578, Long distance no. 901-210-9812

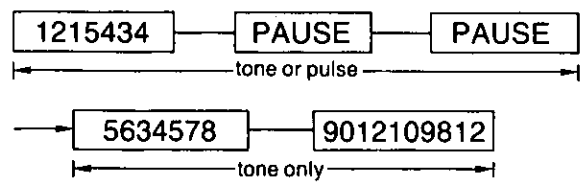

• The above numbers are used as examples only.

Helpful Hints

- Pushing the PAUSE button once counts as 1 digit.
- Switching of the DIALING MODE selector is also counted as 1 digit.

Automatic Call Hunting

If the office which you wish to call has two or more telephone numbers, you can store those numbers (30 digits max.) into one auto/speed dialer station. If one number is busy, the next number will be dialed automatically.

Using One Memory Station

Example:

Store phone numbers 133-2157, 133-0828, and 133-1089 into an upper station.

Storage

Be sure that the handset is on the cradle and that the SP-PHONE button is off.

1 Set to "PROGRAM".

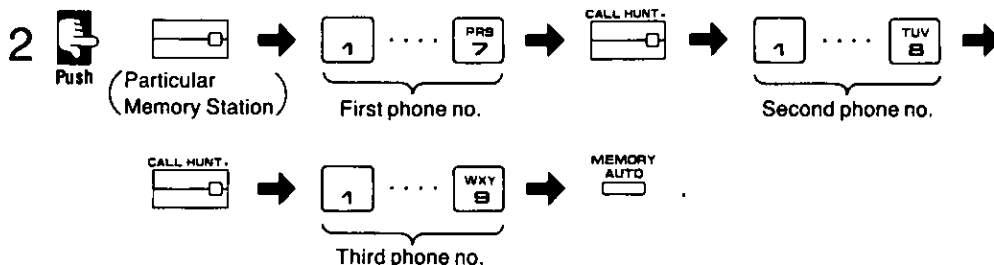

3 After storing all of the numbers, return to "SET".



Dialing

1 Lift the or Push

2 Push (Particular Memory Station)

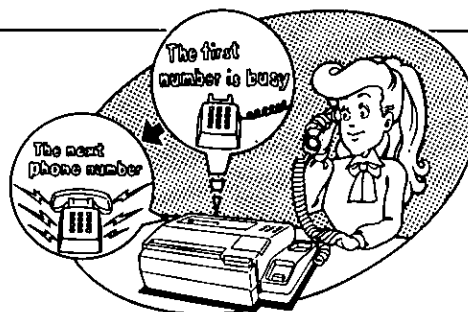

If all of the numbers are busy:

■ When using the handset:



Depressing the REDIAL button causes the numbers to be redialed once.

■ When using the speakerphone:



The unit will automatically redial the numbers dialed up to 15 times.

Helpful Hints

- Phone numbers up to 30 digits can be stored into each station.
- Pushing the CALL HUNT button counts as 1 digit.
- When storing phone numbers into a DIALING button, push the DIALING button instead of a MEMORY STATION button at step 2 of "Storage".

Using Several Memory Stations

If the series of phone numbers which you wish to use for call hunting is too long to be stored in one memory station, you may spread them over several memory stations. However, one phone number may not be spread over two memory stations.

The CALL HUNT button must be pushed once for each phone number, but must not be pushed after the last phone number is entered.

Example:

SPRINT / MCI ACCESS } REAL NUMBER

- Store phone numbers 765-4321, 9123456, 543-210-1122 into an upper memory station (First station).
- Store phone numbers 765-4321, 9123456, 543-210-9876 into another upper memory station (Second station).

Storage

Be sure that the handset is on the cradle and that the SP-PHONE button is off.

Do not push  after the last phone number in the last memory station.

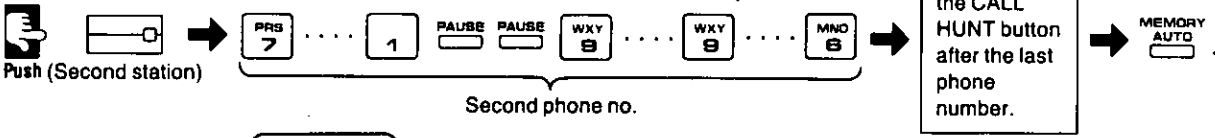

1 Set to "PROGRAM".





3 Return to "SET".



Dialing

1 Lift the  or  

2   then 

Flash Function

You may access some features of your PBX by using the FLASH button instead of the hookswitch.

"Flash" can be stored into memory, the same as Pause in "Programming" on page 7.

Push the FLASH button lightly at the position where the hookswitch operation is required in a dial operation, when programming a memory station.

How to Record an Outgoing Message (OGM)

The purpose of the Outgoing Message is to answer the calling party during your absence.

Recordable OGM chip: Your OGM will be recorded on a voice-recordable microchip.

Prepare and practice your announcement before you record it. Your Outgoing Message is limited to 16 seconds.

Recording and Confirmation

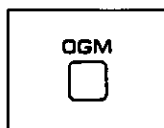

PUSH UNTIL THE INDICATOR LIGHTS



SPEAK INTO MIC

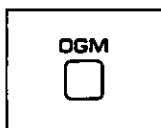

TO FINISH, PUSH AGAIN

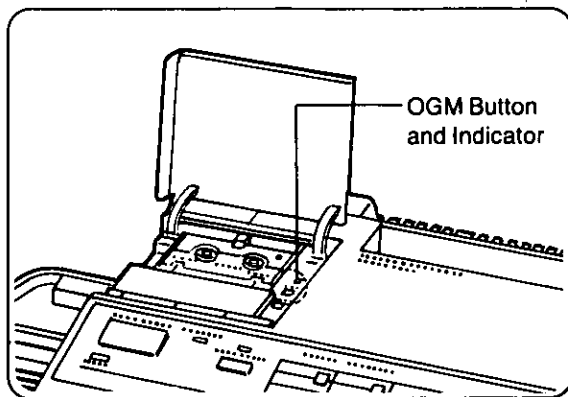

Sample of OGM

- **Set Recording Time to "VOX".**
"This is the Panasonic Company. To send a FAX, push the [*] button. To leave a message, speak after the beep."

- You must record the above or similar message (except for the company's name), since in some cases, the caller will have to push the [*] button to begin transmission, after hearing the OGM.

- For the best facsimile operation, record your OGM within 12 seconds.

- **Set Recording Time to "1 minute".**
"This is the Panasonic Company. To send a FAX, push the [*] button. To leave a message, speak after the beep, up to 1 minute."

1 until a beep is heard and the Push OGM indicator lights.

2 Record the Outgoing Message by speaking clearly and loudly into the .

- Speak about 8 inches away from the MICROPHONE.

- If the OGM is over 10 seconds, the OGM indicator will start blinking to warn you of the remaining time (6 seconds).

3 When you have finished recording your OGM, again. Push

4 The OGM will automatically play back, so that you can confirm the recording.

- Adjust the SPEAKER VOLUME control.

Re-recording

If you want to record again, repeat from step 1 above.

OGM Play Back

quickly. Push

- If you hold the button until the OGM indicator lights, the unit will go into the recording mode.

Even though the Automatic Answer mode is set, an outgoing message can be recorded. At this time the unit will automatically change from the recording mode to the Automatic Answer mode, 7 seconds after the IN USE Indicator goes out.

Prior to Leaving

Preparation before Leaving

Selecting the Caller's Recording Time

Recording time can be set to "VOX" or "1 minute".

Be sure that the handset is on the cradle and that the SP-PHONE button is off.

Recording time is preset to "VOX".

1 Set to "PROGRAM".

- The MEMORY indicator will light.



2 ■ 1 minute: (Limited)

The unit will record an incoming message up to 1 minute.



■ VOX: (Unlimited)

The unit will record an incoming message for as long as the caller speaks.



3 Return to "SET".



To Set Automatic Answer Mode

1 AUTO ANSWER

- The AUTO ANSWER indicator will light.

2 Set the FAX-ATAS selector to "ATAS/FAX", "ATAS" or "FAX". Usually set to "ATAS/FAX".

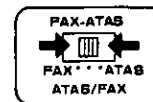

- Before leaving the office, confirm that the AUTO ANSWER and CALLS indicators are lit.
If the FAX-ATAS selector is set to "FAX", the CALLS indicator will not be lit.

FAX-ATAS Selector

■ ATAS/FAX Position

When a call is received, the KX-F115 will answer and begin playing your OGM. If the caller's voice is not heard within 5 seconds of the end of the OGM, the unit will automatically switch to the FAX mode. If a voice is detected, the unit will function as an answering machine.

■ ATAS Position

When a call is received, the unit will function as an answering machine only.

■ FAX Position

When a call is received, the unit will function as a facsimile machine only. No OGM will be played and no messages can be left on the answering machine. Remote operation (from another phone) is also impossible.

Prior to Leaving (cont.)

To Cancel Automatic Answer Mode

If you do not want to set the unit to the Automatic Answer mode;



AUTO ANSWER

again.

Push

- The AUTO ANSWER indicator will go out.
- When the Automatic Answer mode has been cancelled, the following functions will not operate:
 - Transmitting outgoing message and recording incoming message
 - Receiving transmitted document automatically (See "Receiving a Document" on page 25.)

To Prepare the ICM Tape

After reviewing the Outgoing or Incoming message the unit will automatically reset itself to the Automatic Answer mode and will be ready to answer the next call.

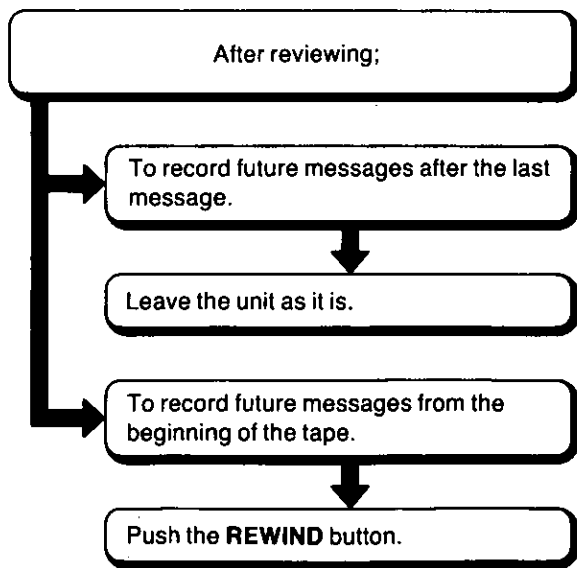

- If you use a new ICM tape, push the REWIND button.

Automatic Answering and Recording

When the telephone rings, the unit will play the outgoing message from the microchip, then it will record the caller's message on the tape, if a voice is heard.

- The CALLS indicator will flash in a group to let you know the number of recorded messages.
- The CALLS indicator will flash up to 15 times, but the unit is capable of recording more messages.
- When power is restored (after a power interruption), the CALLS indicator will flash slowly. Confirm that your recorded OGM is still intact by pushing the OGM button once and releasing it quickly.

While an Incoming Message is being Recorded

Monitoring Incoming Calls

Adjust the SPEAKER VOLUME control.



How to Speak to the Caller Directly

- 1 Lift the  and start speaking.
 - The tape will stop moving.

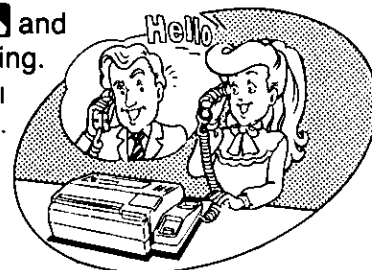

- 2 When you have finished speaking, hang up the .

After Returning to Your Office

How to Use Manual Quick Erase

How to Listen to the Messages



Auto-Logic (One Touch Operation)

At the touch of the PLAYBACK button, the unit will automatically rewind, play back all the recorded messages, and then stop. After 7 seconds, the unit will automatically reset to the Automatic Answer mode. All calls will be automatically saved.

- Future incoming messages will be recorded after the last recorded message. To record new messages from the beginning of the tape, push the REWIND button.

- To stop the tape temporarily,



To restart, push the button again.

- To rewind the tape,



- To fast forward the tape,



How to Save the Previously Recorded Messages

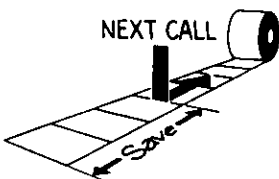

- 1 Play the tape until you hear a beep after messages you want to save, then

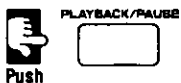

- 2 Push

- The unit will be ready to answer and record future incoming messages after the messages that you saved.

The messages will be erased while rewinding, and the tape will stop automatically when the erasure is completed.

To erase the incoming messages: Wait until the unit plays back the last message and the tape stops.

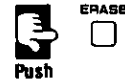

until a beep tone is heard.

- To stop the tape during erasure,

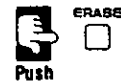

again.

Helpful Hint

The cassette can be erased at high speed even if the record-prevention (knock-out) tabs have been removed.

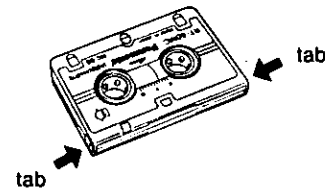

How to Operate from a Remote Phone

You can use a tone phone to listen to your recorded (incoming) messages, from a remote location.

How to Set the Remote Code

A remote code helps to protect from unauthorized remote message retrieval.

Example: Using remote code no. 86.
Be sure that the handset is on the cradle and that the SP-PHONE button is off.

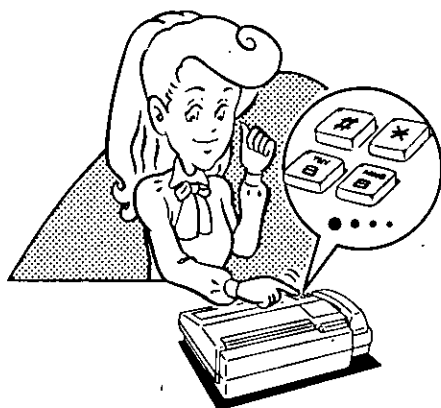

The default remote code (Code No.) is "11".

1 Set to "PROGRAM".

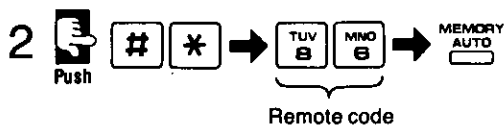

3 Return to "SET".



- The remote code requires two digits.
- Only codes "11" through "99" can be used.
- Do not use No. 0 and No. 7 as Code No.
- The spare quick reference card for remote operations can be found on pages 18 and 19.

How to Set to the Automatic Answer Mode from a Remote Phone

If you leave your office and forget to turn your unit to the Automatic Answer mode, you may do so from a remote location, using any telephone.

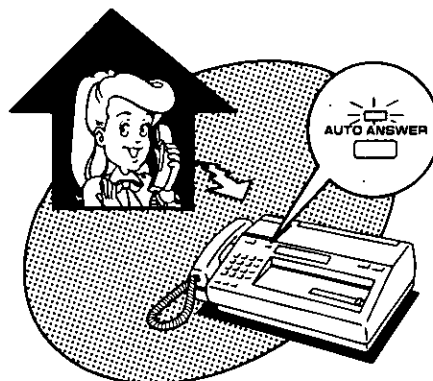

1 Lift the .

2 Dial the phone number.

- After 15 rings, the unit will automatically set itself to the Automatic Answer mode.
- If the FAX-ATAS selector is set to either the "ATAS/FAX" or "ATAS", the unit will begin to play the OGM.

If you do not hang up the handset during or immediately after the playing of the OGM, you will hear several beeps and other tones, as the unit readies itself to receive messages and/or documents.

If the FAX-ATAS selector is set to "FAX", you will hear several "Beeps" (answering carrier tone of your unit).

3 After hearing the OGM or the carrier tone, hand up the .

Helpful Hints

- If you hear nothing, record the OGM.
- The beep will be heard after the OGM.
 - 1 beep: You may hang up.
 - 6 beeps: The tape is full. Reset the tape. (See "Remote Reset of Tape" on page 19).

How to Play Back Messages

Example: Using Remote Code No. 86.

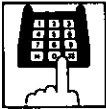

- 

DIAL THE PHONE NO.



PUSH CODE NO. (2 digits) DURING THE OGM
(For example, push 8 [6].)

- A beep will be heard, followed by another 1 to 8 beeps, which represent the number of messages left on your unit.
- The unit will only beep 8 times (max.) even if more messages have been left.
- The unit will rewind the tape and play back all of the incoming messages automatically, even at tape end.
- After all of the recorded messages have been played back, 3 beeps will be heard.

2 Hang up the .

- Future incoming messages will be recorded after the last message.

Back Space and Skip Forward

- To listen to the message again during playback,



- To skip forward to the next message,



- The unit will rewind or skip forward for approximately 15 seconds of playback time and play back the recorded messages.

Memory Playback

When you have already heard your old messages from a remote phone, you may skip them and only listen to the newly recorded ones.

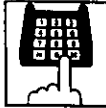
- 

DIAL THE PHONE NO.



PUSH CODE NO. (2 digits) DURING THE OGM

- 

right after you hear the beep
Push GHI 4

tone that tells you the number of recorded messages.

- The unit will play back the new messages.
- To bypass the old messages when they are being played back, push the 4 button. The unit will generate a series of beeps as it advances to the beginning of the new messages.

ANSWERING MACHINE

KX-F115 QUICK REFERENCE CARD FOR TONE REMOTE CONTROL

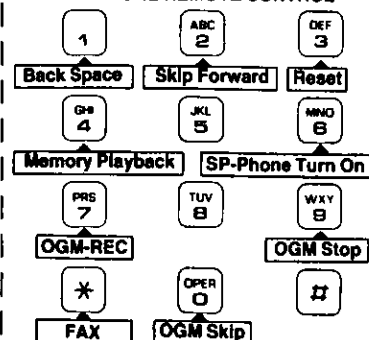

- To set to the Automatic Answer mode remotely
 1. Dial the phone number.
 2. Wait until 15 rings, and hang up after hearing OGM.
- To set to the FAX mode after recording message
 1. Push the * button.
 - The "Beep" (answering carrier tone) will be heard.

How to Operate from a Remote Phone (cont.)

Remote Reset of Tape

To record incoming messages from the beginning of the tape:

After the recorded messages have been played back or while they are playing;

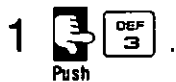

- The unit will rewind to the beginning of the tape and a beep tone will be heard, indicating that the tape has been reset.

After you have used memory playback:

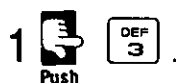

- The unit will rewind to the beginning of the newly recorded messages and a beep will be heard.

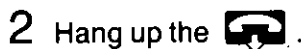
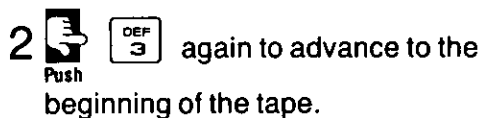

■ **To cancel the remote reset:**

After hearing the beep indicating that the tape has been reset, push the **2** button.

- The unit will play back all the recorded messages again and stop, even if you hang up the handset. Future messages will now be recorded after the last previously recorded ones.

Recording a Marker Message

After playing back all of your messages, you may leave a message for anyone who has access to your remote code.

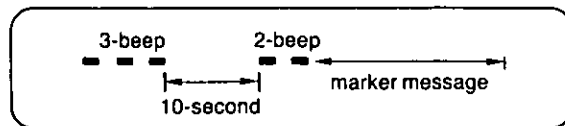

3 beep tones will be heard after the last message has been played, followed by a 10 second pause, and then 2 more beep tones.

- 1 Start speaking right after you hear the last two beep tones.
- 2 When you have finished recording, hang up the .

How to Change the Outgoing Message

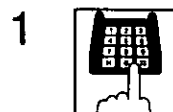

DIAL THE PHONE NO.

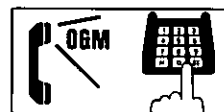

PUSH CODE NO. (2 digits) DURING THE OGM



tones indicating the number of recorded messages.

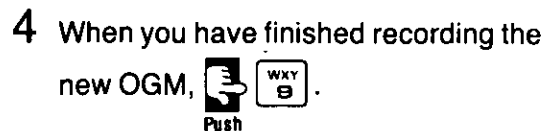
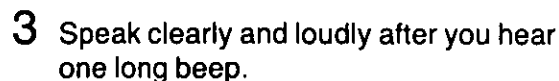

- The new outgoing message will be played back for confirmation.

ANSWERING MACHINE

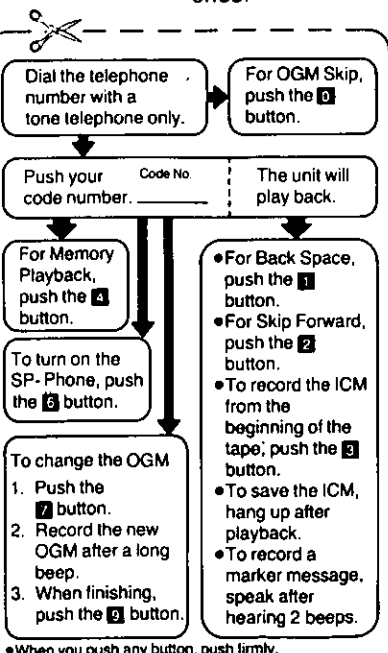

How to Turn on the Speakerphone (Answer-Back)

You may screen the room where the unit is installed, for sound, by turning the speakerphone on remotely. You can speak with anyone in the room, even if they can not reach the unit.

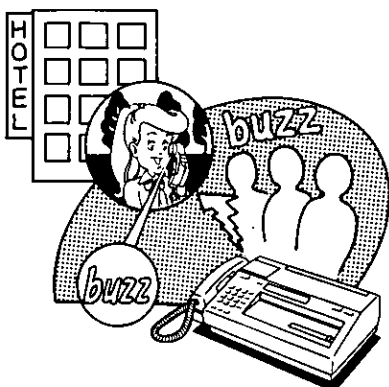

1

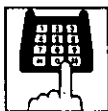

DIAL THE PHONE NO.



PUSH CODE NO. (2 digits) DURING THE OGM

2



right after you hear the beeps.

- The speakerphone of your unit will be turned on.

If you wish to speak with someone in the room;

3 Call to the person to pick up.

4 When the person lifts the  or



, start speaking.

- If no one lifts the handset or pushes the SP-PHONE button, the speakerphone will turn off after 30 seconds.
- To turn on the speakerphone further, push the **[6]** button again within 10 seconds of the beep.

5 When you have finished, hang up the



- Before leaving your office, set the SPEAKER VOLUME control to the position of normal use, otherwise, the other party may not be able to hear your voice.

OGM Skip

If you do not want to listen to the outgoing message, the unit can be switched directly to the incoming message recording mode.

1



DIAL THE PHONE NO.

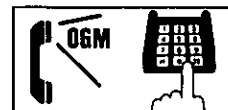

PUSH "0" DURING THE OGM

2 To record your message, speak clearly and loudly after hearing a long beep.



- You can also use this function to call to someone in a room. However, if the SPEAKER VOLUME control of the unit is set to a low position, the person may not be able to hear you through the built-in speaker.

- If a tone telephone is not available, use the optional Panasonic portable automatic dialer (KX-A70).
- In some areas, a remote tone phone may not function, due to telephone line conditions such as line noise, echo, etc.
- The unit may not respond if the tone telephone produces too short a tone.

Message Memo

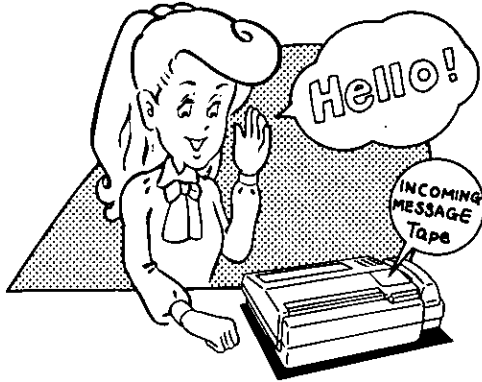
To record a confidential message to be accessed remotely by anyone who knows your remote code number.







- 1  **MEMO/2WAY**
Push
•The IN USE indicator will light.
- 2 Speak your message into the  .
- 3 When you have finished recording your message,  **MEMO/2WAY** again.
Push

•The unit will be ready to answer new calls.

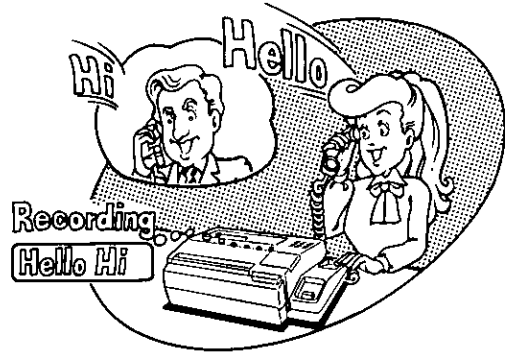
How to Record a 2-Way Conversation

Many States have regulations on the manner in which Two-Way Telephone Conversations may be recorded. Consult your public utility agency.





- 1 Lift the  or  **MEMO/2WAY** **SP-PHONE**, then speak.
Push
- 2  **MEMO/2WAY** until the IN USE indicator lights.
Push
•The unit will produce a beep every 15 seconds, to notify the caller that the conversation is being recorded.
- 3 When you have finished recording,  **MEMO/2WAY** again.
Push
•You may hang up the handset or push the SP-PHONE button.

ANSWERING MACHINE

Transmitting a Document



Recording OGM

To use the unit in the Automatic Answer mode, you should record an outgoing message (OGM) beforehand.

1   until a beep is heard and the OGM indicator lights.

2 Record the Outgoing Message by speaking clearly and loudly into the .

- Speak about 8 inches away from the MICROPHONE.
- If the OGM is over 10 seconds, the OGM indicator will start blinking to warn you of the remaining time (6 seconds).

3 When you have finished recording your OGM,   again.

4 The OGM will automatically play back, so that you can confirm the recording.

Sample of OGM

**"This is the Panasonic Company.
To send a FAX, push the  button.
To leave a message, speak after the beep."**

- You must record the above or similar message (except for the company's name), since in some cases, the caller will have to push the  button to begin transmission, after hearing the OGM.

• **For the best facsimile operation, record your OGM within 12 seconds.**

- For further details, see page 13.
Also see page 25.

Transmissible Document

The KX-F115 can transmit documents with the following sizes, weights and texture.

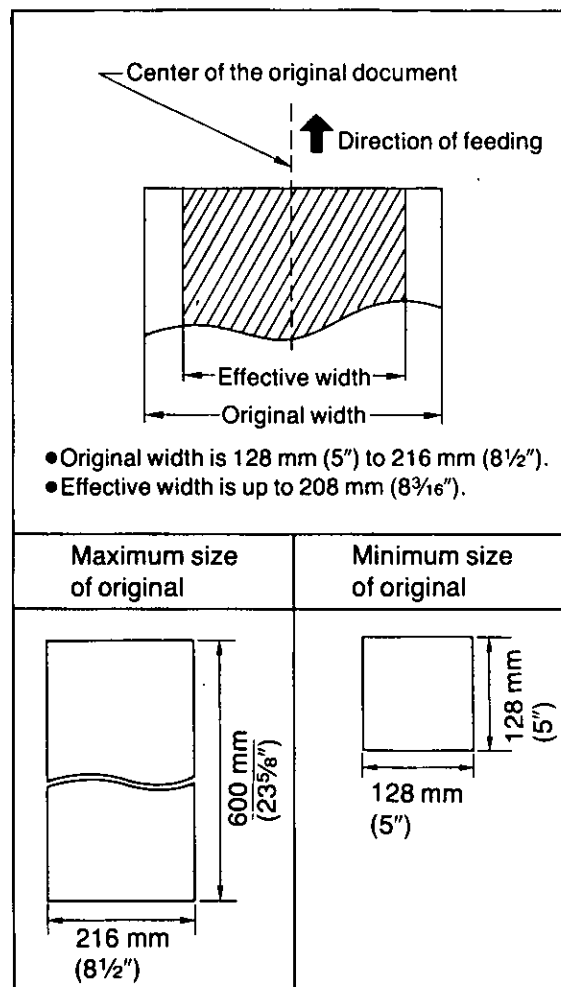

- Original width is 128 mm (5") to 216 mm (8½").
- Effective width is up to 208 mm (8¾").

■ Transmissible document

- Bond paper (16 to 24 pounds)
- Paper with an uncoated surface

NOTE

- A document which is over 600 mm (23⁵/₈") can not be transmitted.
This will be indicated by the lighting of the ALARM indicator and the sounding of the alarm for 3 seconds.
- A document which has staples or clips can not be transmitted.
- Letters on the margin of a A4 size paper may not be recorded.

Transmitting a Document (cont.)

Transmitting

When a document is placed into the unit, the lower memory stations will be automatically selected and the indicator will light. For your convenience, we recommend that you place your most regularly used fax related numbers in these stations.

Begin by transmitting the FAX CORRESPONDENCE leaflet (included) to several of your business associates to confirm that your unit is functioning correctly, and to inform them of the procedure for transmitting documents and/or recording voice-messages on your unit.

1 Place the document face up onto the DOCUMENT holder.

- Place the document against the DOCUMENT guide and insert it into the DOCUMENT holder until it stops. It will then be pulled into the unit by the document feeder.

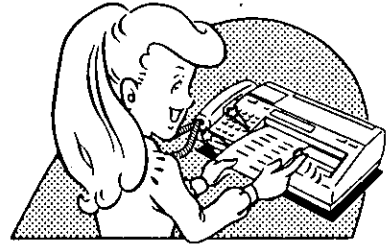

2 Lift the or **Push** .

3 ■ When using an automatic dialer: **Push** (Particular Memory Station) .

- When using a speed dialer:  **Push**  →  to .

- See page 8 for dialing.
- You may dial the phone number manually.

4 After hearing the "Beep" (answering carrier tone of the other party's facsimile), **Push** .

- The FAX indicator will flash.

5 Hang up the .

- If you are using the speakerphone, it would be automatically shut off. The unit will return to the standby mode five seconds after transmission is completed.
- The FAX indicator will change from a flashing to a steady light in a short time, and the unit will begin transmitting the document.
- Remove the document ejected from the DISCHARGE slot immediately, otherwise the next document may not be transmitted properly.

■ If the document does not feed straight when inserting it onto the DOCUMENT holder:

Pull the document out towards you.

■ To transmit continuously:

After the last document is transmitted, three delayed beeps will be heard slowly. When the beeps start, insert the new document (up to 5 sheets) into the DOCUMENT holder.

- When you insert the new document, the beeps will stop immediately.

■ If a document is jammed during transmission:



Open the cover by pushing the LATCH button. Then remove the jammed document by pulling up.

- If you should experience difficulty transmitting/receiving a document (an international fax mainly) because of poor telephone line conditions, refer to page 29 for information on setting the selectors at the bottom of your unit.

- If you are using a call waiting service, and a call is received at the same time that a document is being transmitted, the document may include distorted characters, or transmission errors may occur.

- If a telephone connected in parallel with your unit is used during transmission of a document, your document may be sent with distorted characters.



To Stop Transmission

While transmitting a document,   for approximately 1 second.

- The document will be ejected.
- If document does not feed straight while transmitting, use this procedure.

How to Transmit a Document to Your Unit from a Remote Location

1 Dial the phone number.

2 After hearing the start of the OGM,  .

- The "Beep" (answering carrier tone of facsimile) will be heard.
Your unit will be set to the facsimile mode.

- To record a message after transmitting a document:
After transmission, hang up the handset once then follow the procedure for recording an incoming message.
- To transmit a document after recording a message:

After recording,  .

- Your unit will change from the answering machine mode to the facsimile mode.

Helpful Hints

- When transmitting a document to another KX-F115, at step 3 on page 23, push the  button after hearing the start of the OGM.
- If the letters and/or drawing in an original document are small or intricate, change the RESOLUTION selector to "FINE" to increase the scanning line density.
When you transmit the FAX CORRESPONDENCE sheet, we recommend that you set the RESOLUTION selector to "FINE" that the other party may receive a clear copy.
- The document feeder can handle five sheets of the specified paper. See page 22.
The top sheet of the document will be transmitted first.
- The unit will return to the standby mode, five seconds after transmission is completed.
- If the condition of the telephone line is poor (noisy) or the recording paper of the receiving unit is out, the ALARM indicator will light and a beep will be heard. During these conditions, transmission is not possible.
- When you are transmitting a narrow document, slide the right document guide over to support the document.

Receiving a Document

Be sure that the **AUTO ANSWER** button is on and that the **FAX-ATAS** selector is set to "ATAS/FAX". At this time the **AUTO ANSWER** indicator will light.

The KX-F115 is equipped with a three position FAX-ATAS selector—ATAS/FAX, ATAS and FAX. It will operate as follows according to the position of the FAX-ATAS selector.

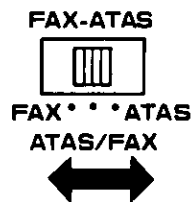

■ ATAS/FAX Position

When a call is received, the KX-F115 will answer and begin playing your OGM. If the caller's voice is not heard within 5 seconds of the end of the OGM, the unit will automatically switch to the FAX mode. If a voice is detected, the unit will function as an answering machine.

■ ATAS Position

When a call is received, the unit will function as an answering machine only.

■ FAX Position

When a call is received, the unit will function as a facsimile machine only. No OGM will be played and no messages can be left on the answering machine. Remote operation (from another phone) is also impossible.

If someone is unable to transmit a document to you after several tries, we recommend the following:

1. Remove the portion of your OGM which says "To send a FAX, push the  button", and ask them to try again.
2. Set the FAX-ATAS selector to "FAX".

■ Tear off the recorded document as shown in the right figure.

■ The unit may not receive a transmitted document if the transmitting conditions (telephone or telephone line etc.) are poor.

■ To receive a document manually:

Even if the Automatic Answer mode is canceled, the unit can still receive a document.

To receive a document after speaking to a caller, push the FAX button; then hang up the handset. The unit will receive the transmission.

■ If a caller hangs up during or immediately after hearing the OGM, the FAX indicator may flash for about 40 seconds but nothing is recorded. This may occur due to differences in Central Office lines and is a normal condition.

■ If you are using a call waiting service, and a call is received at the same time that a document is being received, the document may include distorted characters, or reception errors may occur.

■ If a telephone connected in parallel with your unit is used during receipt of a document, the received document may include distorted characters.

■ When the KX-F115 is used in the facsimile mode for long periods of time, it may overheat and stop operating. Do not turn the power off at this time. Operation will automatically resume as soon as the unit has cooled.



Information on Originals

The following documents should first be copied on a copier machine, and the copy used as the fax document. Or use the exclusive carrier sheet included with your unit.

- Paper with chemically treated surfaces such as carbon-backed paper or carbonless duplicating paper
- Heavily curled, creased or torn paper
- Paper with a coated surface
- Small size paper such as a slip or voucher
- Thin paper
- Wet paper with ink or paste

※ In case of thick paper, make a copy, then use it as a fax document, since a carrier sheet can not be used.

※ When the surface of the carrier sheet has been damaged or fogged, replace it.

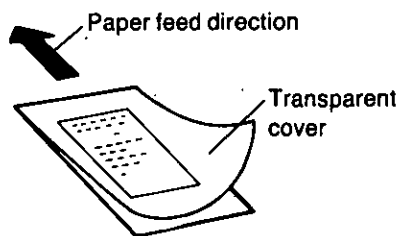
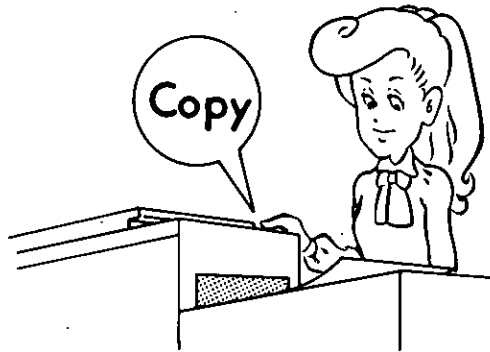

■ How to use a carrier sheet

- 1 Place the original into the carrier sheet with the print facing the transparent cover.
- 2 Place the transparent cover surface face up.
- 3 Place the carrier sheet against the DOCUMENT guide and insert it into the DOCUMENT holder until it stops.

Monitoring a Call

If you receive a call while you are in your office, you can monitor the call as follows:

Be sure that the unit is set to the Automatic Answer mode and that the FAX-ATAS selector is set to the "ATAS/FAX" position.

1 When a call is received, the unit will answer and begin playing your recorded OGM.

2 ■ If the caller's voice is not heard, leave the unit alone.

- The unit will automatically receive the transmitted document.

■ If the caller's voice is heard, lift the handset or push the SP-PHONE button to speak to the caller.

- The caller's voice will be recorded until you lift the handset or push the SP-PHONE button.

※ When the FAX-ATAS selector is set to the "ATAS" position:

Inform the caller who wants to transmit a document that he must push the button after hearing the start of the OGM.

You may speak to the caller by lifting the handset as the caller's voice is heard from the built-in speaker.

If the caller's voice is not heard, push the FAX button to receive a transmitted document as the call will be coming from another facsimile machine.

Making Copy

The KX-F115 can be used to copy single page documents.

Copying

1 Place your document face up on the DOCUMENT holder.

- Place the document against the document guide, and insert it into the document feeder until it stops.
The document will be pulled into the unit.

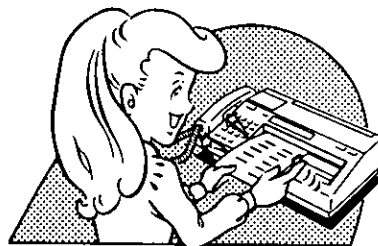

2   .
Push

- When a document is copied, an additional 20 mm of the recording paper will be fed, and a dashed line will be drawn across the bottom.

3 Tear the recording paper.

■ **If the document does not feed straight when inserting it onto the DOCUMENT holder:**

Pull the document out towards you.



■ **To copy continuously:**

After the last document is copied, three delayed beeps will be heard slowly.

When the beeps start, insert the new document (up to 5 sheets) into the DOCUMENT holder.

- When you insert the new document, the beeps will stop immediately.

Copy Pause

While copying,   for approximately 1 second.

- The document will be ejected.
- If document does not feed straight while making a copy, use this procedure.

Helpful Hints

- The unit will return to the standby mode, five seconds after copying is completed.
- Length of originals can not exceed 600 mm.
- A document will be copied in the FINE mode regardless of the position of the RESOLUTION selector.
- The document feeder can handle five sheets of the specified paper. See page 22.
The top sheet of the document will be copied first.

Voice Contact

While you are transmitting or receiving documents, you may wish to speak with the other party. If the other party's unit is equipped with the voice contact feature, you can initiate contact as follows:

Initiating Contact during Transmission

If you initiate voice contact during transmission, you will be able to speak after all of the documents have been transmitted.

- 1 While transmitting the document, lift the  or



- The other party's unit will ring or beep according to the type of the other party's unit after all of the documents have been sent.

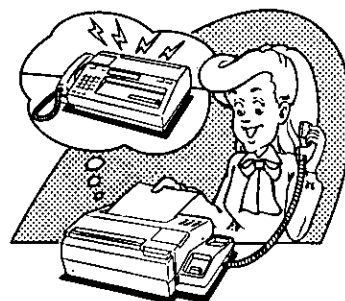

- 2 When the other party answers, start speaking.

Initiating Contact during Reception

If you initiate voice contact during receipt of a document, you will be able to speak after receiving the current page of the document.

- 1 While receiving a document, lift the  or  **SP-PHONE**

- The other party's unit will ring or beep according to the type of the other party's unit after the current page has been sent.

- 2 When the other party answers, start speaking.

Receiving a Request for Contact

If the other party tries to contact you during transmission or reception of a document, your unit will beep after one page of the document has been received.

- 1 If the unit rings while you are transmitting or receiving a document, lift the  or



- 2 Start speaking.



Helpful Hint

When you want to speak to the other party immediately after all of the document have been sent, you need not hang up the handset after pushing the FAX button, as the unit will automatically call the other party if you are using the handset.

Selectors for Facsimile

When you peel off the PROTECTION cover at the bottom of the unit, you can find several selectors for facsimile. These selectors have been set to the following positions beforehand, so you need not operate usually.

- ① **CABLE EQUALIZER Selector:**
Usual position is "OK".

- ② **TRANSMITTING LEVEL Selector:**
1: Usual position is "OFF".
2: Usual position is "OFF".
4: Usual position is "OFF".
8: Usual position is "ON".

- ③ **G3 TRANSMITTING SPEED Selector:**
Usual position is "OFF". (9600 bps)
• "ON" position indicates 4800 bps.

- ④ **G3 RECEIVING SPEED Selector:**
Usual position is "OFF". (9600 bps)
• "ON" position indicates 4800 bps.

- ⑤ **MODEM EQUALIZER Selector:**
Usual position is "ON".

- ⑥ **CED FREQUENCY Selector:**
Usual position is "OFF". (2100 Hz)
• "ON" position indicates 1100 Hz.

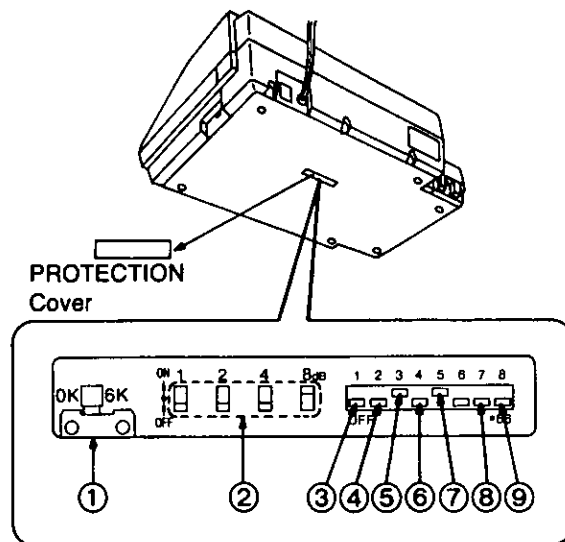

- ⑦ **INTERNATIONAL MODE Selector:**
Usual position is "ON".

- ⑧ **MODEM TEST Selector:**
Usual position is "OFF". (NORMAL)
• "ON" position indicates "TEST".

- ⑨ **OFF-HOOK DETECTION Selector:**
Usual position is "OFF".
(OFF-Hook Detection will function.)

- If you experience problems caused by poor line conditions, change the position of selector ① and ③. Before changing the position of any other selectors, consult with the specified Panasonic Factory Service Centers.

- 1 If the voice of the other party is usually low during the speakerphone mode:
Change the CABLE EQUALIZER selector to the "6K" position.
- 2 If the FAX indicator usually flashes for more than 20 seconds after pushing the FAX button to begin transmission:
Change the G3 TRANSMITTING SPEED selector to the "ON" position.

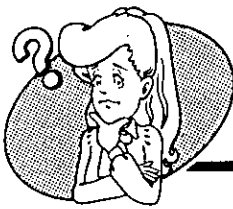

Troubleshooting Guide

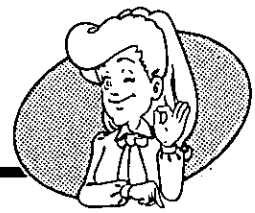

Problem

Cause & Remedy

Telephone

The unit does not ring.

- Ringer Volume Selector is set to "OFF". Should be set to "HIGH" or "LOW".
- The Automatic Answer mode is set and the FAX-ATAS selector is set to "FAX".

The caller suddenly cannot hear my voice during a conversation.

Look at the MUTE indicator. If it is lit, push the MUTE button to resume the conversation.

I suddenly cannot hear the caller's voice during a conversation.

Look at the HOLD indicator. If it is blinking slowly, push the HOLD button to resume the conversation.

Answering Machine

- The unit does not work when I push the buttons.
- I cannot remove the cassette from the unit.

- Unplug the AC cord and plug it in again then switch the power on.

The unit has been set to the Automatic Answer mode, but no incoming messages have been recorded.

- The microcassette is broken (cut, worn out or twisted) or not inserted. Replace the cassette with a new one.
- The OGM is recorded improperly. Record a new OGM.
- The FAX-ATAS selector is set to the "FAX" position. Change the selector to the "ATAS/FAX" or "ATAS" position.

When the tape is played back, the sound level is low, even if the SPEAKER VOLUME control is turned up fully.

Clean the heads. (See "Maintenance" on page 10 in INSTALLATION MANUAL.)

I have played back all the recorded messages and I want to record the next phone call after the last previously recorded message.

- When the AUTO ANSWER indicator starts blinking, wait for 7 seconds. When the AUTO ANSWER indicator is off, push the AUTO ANSWER button. The unit will be ready to record next phone call.

I push the buttons of a remote phone, but the unit does not respond.

- Make sure that you are using the correct code number.
- Record the outgoing message in a quiet place.

Some incoming messages have not been fully recorded.

Set the CPC switch to the "B". See "Telephone Line Connection" page 9 in INSTALLATION MANUAL.

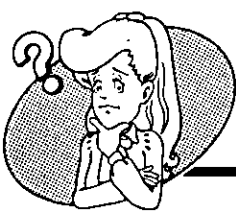

Troubleshooting Guide (cont.)

Problem

Cause & Remedy

Speakerphone of the unit cannot be turned on from a remote phone.

The MEMORY switch of the unit is set to "PROGRAM". If the Switch is returned to "SET", the unit will operate normally.

The POWER indicator does not light when the POWER switch is turned on.

Confirm whether the AC cord is plugged in or not.

Facsimile

The ALARM indicator lights during transmission.

- Confirm whether the cover is closed completely or not.
- When copying or receiving documents for long periods of time, the unit may overheat. In this case, turn off the POWER switch and allow the unit to cool.
- When you transmit a document which is longer than 600 mm, the alarm may sound. Turn off the POWER switch, open the cover and remove the document.
- The recording paper of the other party's facsimile may be out.
- If you have call waiting service, it may have been activated by another telephone call. Re-connect the unit to no call waiting serviced line.

Recording image is scratchy and can not be read completely.

The other party transmitted a light density document. Have the other party darken the density of a document (e.g. by copying) then have them transmit it again.

The document is not pulled into the unit.

If the document is not properly inserted into the DOCUMENT holder, it may not be pulled into the feeder. Insert the document sufficiently until it stops.

The document jammed during transmission.

● A scrap of paper may be jammed into the unit. Open the cover by pushing the LATCH button and remove the scrap.

The other party complains that documents are being received with distorted letters.

- Someone may have used a telephone connected in parallel with the KX-F115.
- If you have call waiting service, it may have been activated by another telephone call. Re-connect the unit to no call waiting serviced line.



Problem

Cause & Remedy

The unit has been set the Automatic Answer mode, but a document can not be received automatically.

- The FAX-ATAS selector is set to the "ATAS" position. Change the selector to the "ATAS/FAX" position.
- Confirm whether you have recorded the following OGM—"To send a FAX, push the [*] button" or not. See page 22. For all that, if transmission cannot be done, see page 25.

When using an automatic dialer, I cannot dial the other party's FAX number.

- Confirm whether the FAX number has been stored into the lower memory station or not.
- Confirm whether you untouched the LOWER STATION button or not.
- ※ When you set your document to the unit, the unit will automatically select the lower memory station and the LOWER STATION indicator will light. So you need not push the LOWER STATION button.

The FAX indicator flashed for about 40 seconds after your unit receives a call automatically but nothing is recorded.

A caller hung up during or immediately after the playing of the OGM.
This may occur due to differences in Central Offices and your unit is normal condition.

The following sections can be found in INSTALLATION MANUAL.

- Replacing Recording Paper
- Battery Replacement
- Telephone Line Connection
- Cassette Tape
- Maintenance
- Others
- Important Information
- Specifications of Facsimile
- Servicenter Directory
- Accessory Order Information
- For Your Future Reference
- Warranty

Glossary of Terms

ATAS : Automatic Telephone Answering System

OGM : Outgoing Message

CPC : Calling Party Control
Calling party control enables the unit to detect when a caller hangs up.

VOX : Voice Activated Circuit
The caller can leave a message for any length of time for as long as he/she continues to speak.

Flash : If you connect your unit to PBX, you may access some features of your PBX by using the FLASH button instead of the hookswitch.

Panasonic Company
Division of Matsushita Electric Corporation of America
One Panasonic Way, Secaucus, New Jersey 07094

Panasonic Hawaii, Inc. ("PHI")
91-238 Kauhi St. Ewa Beach, Honolulu, Hawaii 96808-0774

Panasonic Sales Company ("PSC"),
Division of Matsushita Electric of Puerto Rico, Inc.
Ave. 65 De Infanteria, KM 9.7 Victoria Industrial Park, Carolina, Puerto Rico 00630